

# DH300



## Model DH300

The Model DH300 is an extremely versatile and dependable machine designed specifically for briquetting operations requiring moderate to high pressures while optimizing production rates. Applications are numerous and include carbon based fuels, inorganic chemicals such as table salt, mineral ores, industrial by-products, and metal powders.

### Features:

- Solid or segmented roll design for easy roll replacement
- Vertical feed design provides for either screw feed or gravity feed options
- Pockets are available in different shapes and sizes
- Vacuum de-aeration available for fine powder applications
- Variable speed roll and screw feeder drives to maximize product quality
- Rolls and feed screws are available in wear & corrosion resistant alloys
- Robust and extremely stable industrial frame construction
- Heavy duty long lasting bearings and drive components
- Designed for ease of maintenance

## Model DH300 General Specifications

Roll Diameter	13 - 20.5 in	330 - 520 mm
Roll Width	4 - 13 in	150 - 330 mm
Maximum Roll Separating Force	75 ton-force	670 kN
Roll Drive (Typical)	75 hp	56 kW
Feeder Drive (Typical)	15 hp	11 kW
Throughput Range (Depending on briquette size and density)	2 - 10 t/h	2 - 9 mt/h
Machine Weight (Typical)	21,700 lb	9,850 kg

## Model DH300 General Arrangement and Dimensions

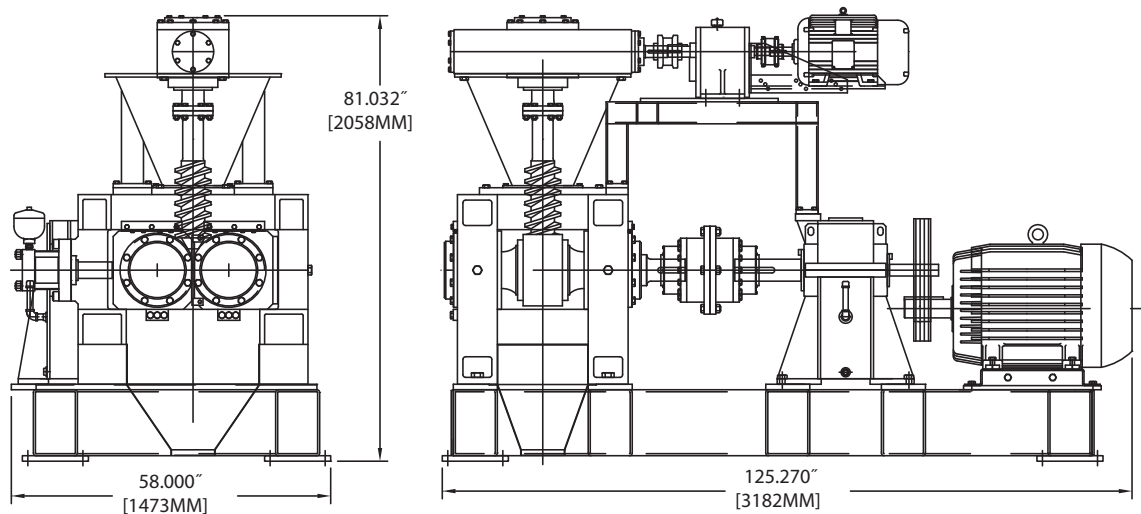

## Typical Applications

KOMAREK DH300 is suitable for a variety of applications, including:

Lime	Sodium Cyanide	Aluminum	Chemicals
Minerals	Steel Mill Waste	Molybdenum	Lithium Carbonate
Charcoal	Nickel Latherite	Coal	Bentonite
Salt	Calcium Hypochlorite	Metallic Cobalt	Maleic Anhydride

